

Building over or near a public sewer.



www.developers.thameswater.co.uk



0800 009 3921
Monday to Friday, 8am to 5pm



If you're planning a new building, a conservatory, a garage or any other extension to your home, it's important you let us know. We need to make sure your work doesn't accidentally affect a sewer, or limit our access if we have to repair it.

Once we're happy with your proposals, we'll issue a 'build over' agreement. You need to apply for one if you're building:

- Within **3 metres** of a pipe serving more than one property – known as a public sewer
- Within **1 metre** of the point where a pipe serving only your property crosses your boundary – where it becomes a public lateral drain

We offer two types of build over agreement, depending on the type of work you're planning and the history and position of the pipe you're building near.

The two types of build over agreement

If you're building over or near a **domestic sewer** with a diameter of **160mm or less**, you can potentially apply for a **self-certified build over agreement**. We may grant this if you're able to confirm that your plans pose little risk to the pipe.

This free service is only available online, and requires you to complete a questionnaire at developers.thameswater.co.uk/buildover.

If your answers don't meet our requirements, we'll redirect you to apply for an **approved build over agreement**, for which you'd need to pay. You'll need to apply for this approved agreement if you're unsure of any of the answers, or if you want to build over or near a sewer with a diameter above 160mm.

Why is it important to get a build over agreement?

The agreement is our seal of approval for any building work you're planning over or near a sewer we own.

We're responsible for all public sewers and public lateral drains in our region. We need to be certain your building work doesn't restrict our ability to maintain and repair these pipes. And we also need to be certain that the extra weight of your new building doesn't damage the pipe.

Without a build over agreement, your local council's building control department might not sign off your Building Regulations completion certificate – and without this, you may have problems when trying to sell your property.

We have legal powers, under Sections 159 to 171 of the Water Industry Act 1991, giving us the right to maintain, repair, replace and renew public sewers. If any building work limits this, we could seek an injunction to remove the building and potentially recover damages.

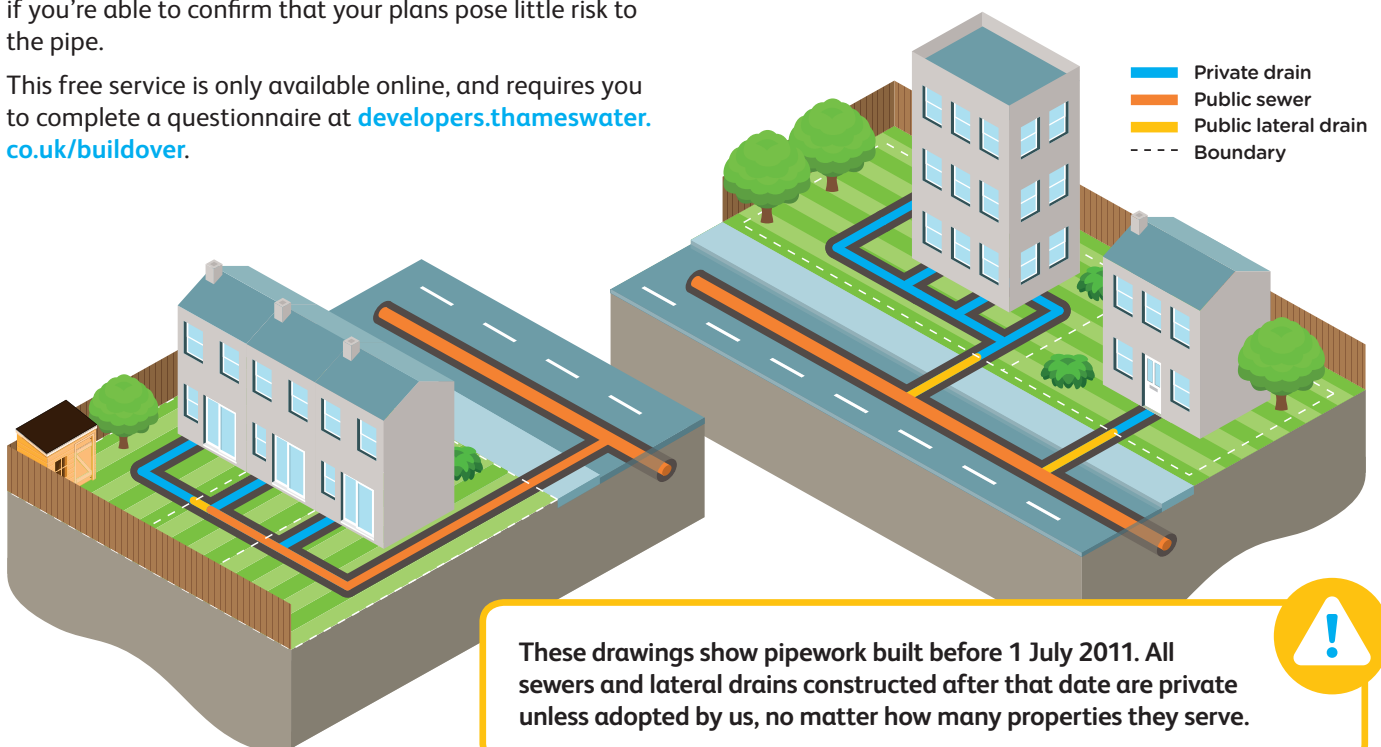

Who is responsible for drains and sewers?

The start of the drain is the responsibility of the property owner until it crosses the boundary into land owned by someone else. At that point it becomes a public lateral drain.

Once a second property connects into the public lateral drain, it becomes a public sewer.

We're responsible for all public sewers and lateral drains in our region.

The drawings on page 2 show typical examples of the different types of drain and sewer.

Different sewer sizes

We group sewers into three sizes, which determine the type of application you can make and the amount of survey work required.

Class 1

If the sewer you're building over or near is **up to and including 160mm in diameter**, you may be eligible for a self-certified agreement or may require an approved agreement.

Class 2

You need to apply for an approved build over agreement if the sewer you're building over or near is from **over 160mm to 375mm in diameter**. We'll carry out a pre-construction CCTV survey to check whether any repairs are needed. We'll also carry out a second survey when your building is complete, to make sure the sewer hasn't been damaged.

Class 3

You also need to apply for an approved build over agreement for sewers **over 375mm in diameter**. In this case, we may need to enter the sewer to carry out our pre- and post-construction surveys rather than using a camera.

How much does the application cost?

A self-certified build over agreement is free but can only be applied for if you're building over or near a domestic sewer up to 160mm in diameter. You'll also need to meet all of our criteria, explained on page 5.

The cost of an approved build over application depends on the size of sewer and whether your property is domestic or commercial.

Diameter	Property type	Cost
Class 1 Up to and including 160mm (6")	Domestic	£343 or £299 when applying and paying online
Up to and including 160mm (6")	Commercial or new build	£687
Class 2 Over 160mm (6") to 375mm (15") inclusive	Any	£687
Class 3 Over 375mm (15") inclusive	Any	£1,300*

*There is also a legal fee involved in entering into an agreement for sewers over 375mm in diameter, which is usually around £550. If you apply online you can pay using a credit or debit card.

There are alternative costs if you are a disabled applicant. Please read the section of the application form headed 'Working out the cost'.

What does the fee cover?

For Class 1 sewers, the fee covers:

- Processing your application
- Technical reviews of your plans
- Discussing and agreeing any design change proposals
- Liaising with your building control officer
- Issuing your agreement
- Registering the agreement to build over or near the public sewer on our records

For Class 2 sewers, it funds all of the above, plus two surveys of the length of affected sewer (pre- and post-construction).

For Class 3 sewers, the fee again covers all of the above but the two surveys are likely to take a lot more time and be much more expensive.

Locating a sewer and where your property connects to it

You need to locate any sewers to find out how close you're building to them, and to work out who owns them. Sewers often run beneath back gardens, particularly in urban areas. You may want to contact a drainage specialist for help.

The first step is to look for a manhole. Please take care if you open it – covers are heavy and you may need help.

- If you open the manhole and find the pipes form a junction as shown in the middle and right-hand photos below, your property is part of a shared run of pipework to which other properties are connected.

- If the pipe is in an 'L' shape, you may be able to visually plot where it is running. For example, the pipe might leave your house before crossing other gardens. Or it could be the last point before the sewer connects into the pipe running under the road outside the property.

Alternatively, if there's a mapped public sewer on your land, you can check its location by:

- Visiting your local authority offices to inspect their sewer maps
- Contacting our Property Searches team via thameswater-propertysearches.co.uk or on 0845 070 9148 (9am to 5pm on weekdays)

Please note that nearly half of public sewers in our region don't appear on our records. This is because they were privately owned until 2011, when a legal change transferred them to our ownership. So we sometimes need you to tell us where the sewers on your property are.

If you need to trace a sewer or drain yourself, we've described some commonly-used methods below.



If there are no visible manholes, try visually plotting the likely course of the sewer by studying nearby manholes. Carefully dig a trial hole or trench to locate the pipe.



Once you've carefully opened a manhole, you can often work out the direction of flow by turning on a tap or flushing a toilet in your property, then seeing which way the water runs. You might need a torch to help you see. This should help you work out where your property connects in relation to others.



You could try putting dye into your toilet and flushing it, and/or doing the same from a neighbouring property with a different colour dye. This can show where the properties connect into the sewer, as well as the direction of flow.

If you need further advice, you can email drawings or photos to us at developer.services@thameswater.co.uk.



Self-certified build over agreements

We'll only provide a self-certified build over agreement if your proposals meet **all** of the following criteria:

- **You're building a single or double storey residential extension, conservatory, garage or annex, attached to an existing property.**
- **There must be no problems you're aware of with the sewer, like blockages, flooding or smells.** If there are, we'll potentially give approved consent when they've been resolved, or can be, and so long as there are no other issues with the local sewers.
- **Access points such as manholes, inspection chambers or rodding eyes will be outside your new building and at least 500mm away.** If not, you can potentially gain consent by changing the shape of your building to comply with this. Or we'll potentially give approved consent if you can reposition the access point to a suitable agreed standard.
- **The sewer must not change in diameter, direction, material or gradient beneath or near your planned building.** If it does, we'll potentially give approved consent if you or your builder replaces or realigns the pipe before starting work. This will ensure the pipe runs straight between any access points located outside your building.
- **The sewer must be no more than two metres below ground.** If it's deeper, we'll potentially give approved consent if your plans show that your work places minimal extra load – or none at all – on the pipe.
- **The sewer must be no more than 160mm in diameter.** Whatever its size, we'll potentially give approved consent if you protect the pipe before starting work. Let us know if you need guidance.
- **The sewer must be made of clay or plastic.** If it's made of concrete, pitch fibre, brick or asbestos cement, we'll potentially give approved consent if you protect or, in some cases, replace the pipe before starting work.
- **You must achieve the minimum clearances shown in the drawing on pages 6 and 7.** If you can't, we'll potentially give approved consent after a detailed assessment of your foundations. If you're unable to provide 300mm of cover between the sewer and the underside of the new floor, we'll potentially give approved consent if the pipe can be diverted outside the building.
- **Your building will have traditional strip or trench fill foundations.** If it uses another form of foundation design, such as pad, piling, raft or cantilever, we'll potentially give approved consent only after a detailed assessment of your foundations.
- **The sewer must be in good condition.** You can check by exposing the length of pipe you'll be building over, or by getting a drainage CCTV contractor to survey the inside of it. If there are defects, we'll potentially give approved consent if you or your builder replaces the pipework.
- **There are no easements or covenants relating to the sewer.** These documents are often kept with a property's deeds, and it's your responsibility to check if there are any before completing our self-certification questionnaire. If an easement or covenant exists, we'll potentially give approved consent if you submit it with your application.
- **If you're building across the full width of your garden, the sewer can still be accessed via a neighbour's garden.** For further details, see page 7.



If you're not sure about any of the above points, you could seek advice from your architect, builder or your local council's building control department. If you're still unclear, or these points don't accurately describe your situation, you should apply for an approved build over agreement.

Example requirements for a self-certified build over agreement

These drawings show some of our key requirements in order for your proposed building work to qualify for a self-certified build over agreement.

We've shown a conservatory in our drawing, but the conditions apply to any of the structures described in our checklist and terms and conditions.

The illustration on this page shows minimum clearances and some of our other key requirements if you're building near a sewer. In each case:

The example below shows minimum clearances and some of our other key requirements if you're building over a sewer.

- 1 Diameter of pipe must be no larger than 160mm
- 2 Granular surround must be no less than 150mm around the pipe



- 3 No loadings placed on top of the pipe from the proposed dwellings – for example, a lintel has been used in this case

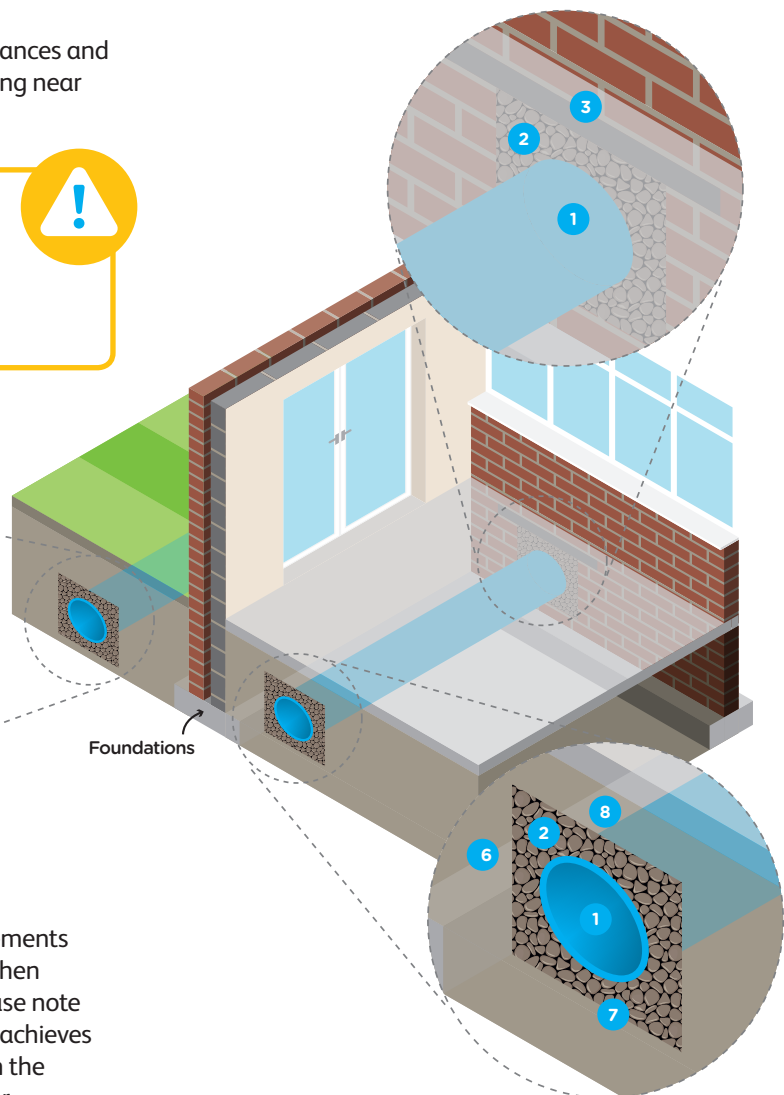
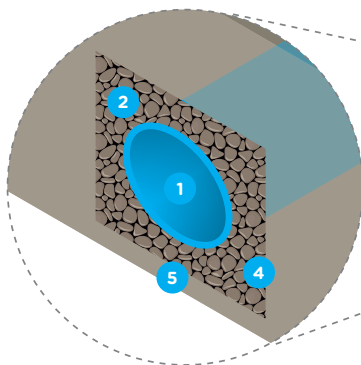

The example above shows some of our key requirements if a sewer passes through a wall you're building. When answering our self-certification questionnaire, please note that any sewer outside the building automatically achieves the minimum 300mm clearance required between the underside of the floor slab and the top of the sewer.

- 4 Pipe to be at least 500mm away from parallel foundations
- 5 Pipe to be at least 150mm above the bottom of the foundations when building within 1 metre



- 6 Pipe to be at least 500mm away from parallel foundations
- 7 Pipe to be at least 150mm above the bottom of the foundations
- 8 Top of pipe to be at least 300mm from underside of floor slab



Maintaining access to sewers running under gardens

If you're planning to build over a sewer across the full width of your garden, we won't allow a self-certified build over agreement unless the sewer can still be accessed via a neighbour's garden. This is shown in drawing 1 below.

If your neighbours have also built across the width of their gardens, this would prevent us accessing the sewer across three or more adjacent properties.

To avoid this, you can potentially receive self-certified consent by changing the shape and/or position of your proposed building, as shown in drawing 2 below. This would allow us to access the sewer if we needed to maintain or repair it.



- 1 A conservatory here has been built in the garden of the middle property, meaning there's no access to the manhole in this garden. In this instance, we won't allow a self-certified build over agreement. You'd need to contact us to discuss options for a potential approved build over agreement, for which there is a charge.
- 2 The footprint of the conservatory here has been altered so that there's still access to the manhole. We will potentially allow a self-certified build over agreement in this case.

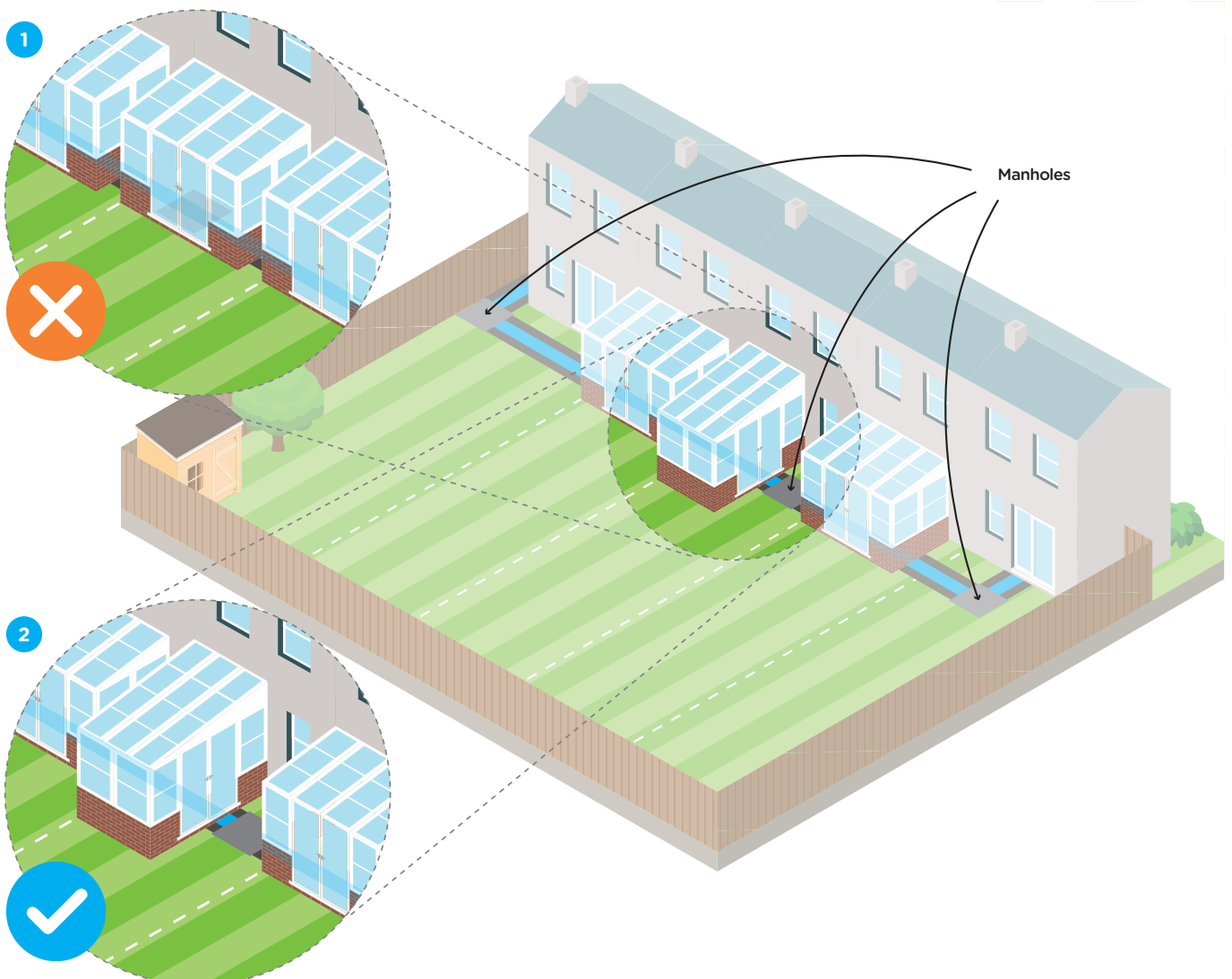

Drawings to include with your approved build over application

We've included here examples of the drawings you need to include when making a approved build over application.

We require you to submit a cross section drawing if you're building over or within 1.5 metres of the sewer, as we need to see how the foundations will be constructed. You must show the foundations in relation to the sewer, marking the clearance and providing the detail of any bridging over.

If you're unsure whether you're building within 3 metres of a sewer, you should send us a ground floor plan, with the location of the sewer clearly plotted. Please also include any manholes or inspection chambers, and show the direction of flow.

Postal applications

You can apply online or by post. Postal applications should be sent to:

Thames Water Developer Services
Clearwater Court
Vastern Road
Reading
RG1 8DB

You can send us a cheque payable to Thames Water Utilities Ltd with your application form. Please write the site address on the back of the cheque. Or you can opt to pay by credit or debit card, and we'll contact you to make payment over the phone.

Once we receive the application we'll review your plans to ensure that the proposed works fully comply with our specifications and won't damage our sewer.



Drawings required for all applications

Existing building and drainage layout

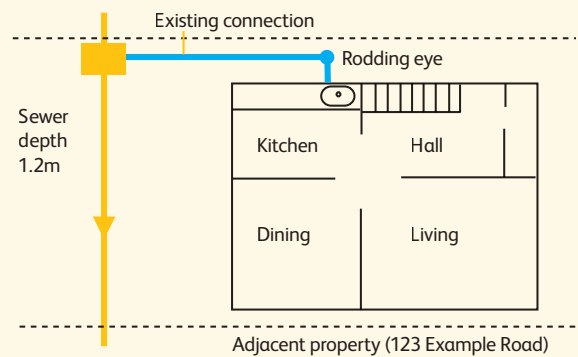

This must show the sewer, manholes and flow direction in relation to the existing structure, and any connections into the sewer.

Site location plan

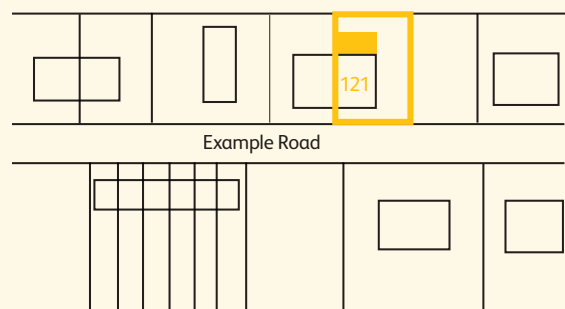

This must show the location of the property (indicated here in colour) in relation to neighbouring properties.

Building near a sewer

Proposed extension and drainage layout

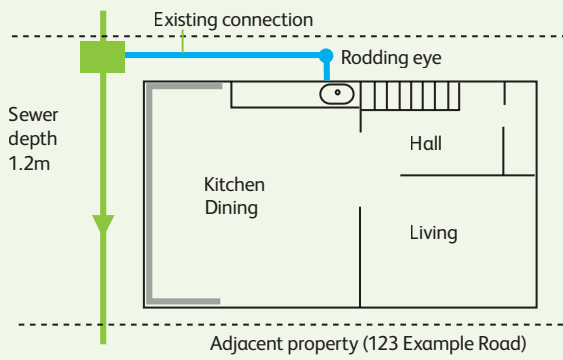

This must show the sewer, any manholes and flow direction in relation to the proposed structure, and any connections into the sewer.

Cross section

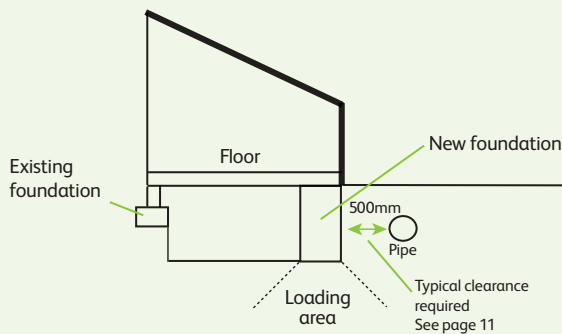

If you're building within 1.5 metres of the sewer, you'll need to include a cross section drawing like this, showing your foundation design in relation to the pipe.

Building over a sewer

Proposed extension and drainage layout

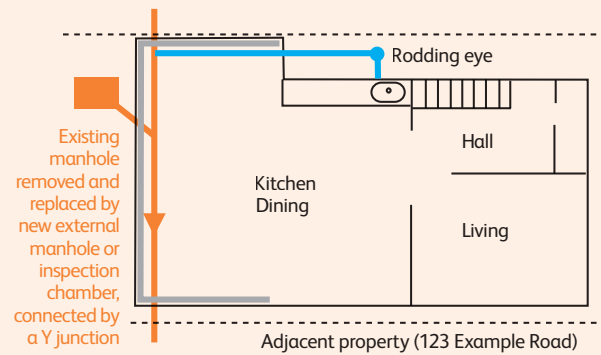

This must show the sewer, any manholes and flow direction in relation to the proposed structure, and any connections into the sewer. Suitable external access to the sewer must be maintained.

Cross section

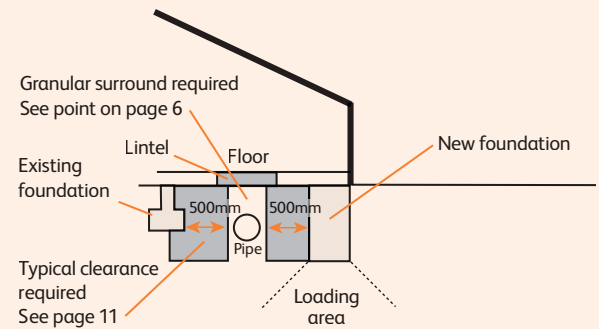

If you're building over the sewer, you'll need to include a cross section drawing like this, showing your foundation design in relation to the pipe.

You'll also need to bridge the sewer with a concrete lintel at the point where the sewer passes through the foundation walls.

Approved build over agreements

If you don't qualify for a self-certified build over agreement or are unsure whether or not you qualify, we'll work with you so that you can achieve approved consent for your building work.

We'll guide you through the process and suggest any changes you might need to make to your proposals.

When can't I build over a sewer?

There are some cases in which we won't allow you to build over a sewer. These include:

Rising mains

These are pressurised sewers which pump foul sewage or rainwater. The cost of diverting the sewer and upgrading the pumps is likely to run into tens of thousands of pounds, so will probably be outside your planned budget if you're carrying out domestic or small commercial developments.

Manholes

We don't allow internal manholes, even if they have double-sealed covers, because there's an increased risk of internal flooding and odour problems. You'll need to remove the manhole and lay a new section of connecting pipe across this section. You should reconstruct the manhole outside your extension, either on the line of the sewer or offset and connected by a Y junction (see drawing on page 9). We'll work with you to suggest suitable options for relocating manholes, where possible.

Strategic sewers

Strategic sewers are the most significant in our wastewater network, and we won't allow some of them to be built over.

You shouldn't start work before getting our consent. If we need to agree amendments to your design, it's difficult to do so if you've begun work, and could cause you additional costs or delays.

Minor sewer diversions

We may allow your contractor to divert a sewer with a diameter of 160mm or less, subject to the following:

- A pre-construction CCTV survey
- A post-construction inspection and CCTV survey

You can request these by completing an approved build over application, showing your proposed diversion in your plans.

Options on a new detached development

In most cases, we won't permit you to build over a sewer on a new detached development. We'll instead require a sewer diversion, at your cost. The diversion process depends on the size of the pipe. Please call us on 0800 009 3921 for more information.

If your proposals could affect a public sewer, you should first consider the following options:

- **Avoid the sewer** by modifying your plans so that the buildings are at least 3 metres from the sewer. This is often the easiest and cheapest option.
- If you can't do this, we'll usually require you to **divert the sewer**. In many cases, we'll allow your contractor to do the work. Please call us on the above number if you want to discuss this option.

New sewer connections

If you're connecting a property to the sewer for the first time or increasing the number of connections to the sewer, you may need further approval before you go ahead. We'll need to check that the connection will work, and that it won't cause problems like sewer flooding or pollution. We have legal duties around this, set out in Section 94 of the Water Industry Act 1991.

As part of this approval you'll need to give us details of the drain to be connected and how the connection will be made. You'll be responsible for costs associated with the application and carrying out the connection. The connection can be made by your choice of qualified contractors, unless it's to a trunk sewer, in which case we'll need to carry out the work for you.

If your proposals include a surface water or combined connection, we'll require you to explore sustainable methods for disposing of the surface water. You can find out more about our preferred methods at [thameswater.co.uk/sewerconnections](https://www.thameswater.co.uk/sewerconnections), or by calling us on 0800 009 3921.

Specifications for approved build over agreements - Sewers up to 160mm in diameter

These are our general guidelines when building within three metres or over a public sewer that is **up to 160mm** in diameter.

1. All new works must be done in like for like materials and comply with the requirements of the latest version of 'Sewers for Adoption', in conjunction with 'Protocol on Design and Construction of Adoption of Sewers in England and Wales'.
2. This consent is subject to any conditions that may be imposed through the Building Regulations process.
3. **New dwellings are not permitted to be constructed over the public sewer.**
4. Your proposed works must not transmit any additional loads to the sewer.
5. Prior to work starting on your site, it is your responsibility to check and verify the position of the public sewer and the depth of the bottom of the pipe.
6. Any sewers that are up to 1.1 metres deep, from ground level to the bottom of the pipe, must run a minimum of 150mm away from the foundations.
7. Any sewers where the bottom of the pipe is more than 1.1 metres below ground level must run at least 500mm away from the foundations. If it is more than 2.0 metres below ground level, any proposed foundations must be at least 1.0 metre from the sewer.
8. All surveys carried out will be at the householder's expense.
9. Any piled foundations are subject to our approval and will require additional surveys to be carried out. They must be constructed a minimum of twice the pile diameter or 1.5 metres (whichever is greater) from the outside of the pile to the outside of the sewer.
10. We will not allow driven piles within 15 metres of a public sewer.
11. **Manholes on the public sewer must not be built over or located inside proposed structures, even with new double-sealed bolt down covers.**
12. Where the public sewer is up to 1.1 metres deep, no structure must be built in contact with the public sewer manhole, and must be a minimum of 150mm from the outside of the chamber wall.
13. Where the public sewer is more than 1.1 metres deep, no structure must be built within 500mm of the public manhole.
14. New connections on our existing sewer network must be constructed in like for like materials and should be via a manhole or a pre-formed junction. Saddle connections are not permitted on these sewers.
15. Connections into manholes must be made with soffit to soffit and must enter 'with the flow'.
16. We will not accept the public sewer being continuously built over for four or more properties in a row, without a suitable external manhole being available for operational access.
17. New manholes on our existing sewer network must be constructed in like for like materials and in line with the requirements of the latest version of 'Sewers for Adoption'.
18. Please note that sewers of this type are occasionally found to have minor defects such as misaligned joints (often since new) or hairline cracking. In such cases, we would accept the sewer as being in a serviceable condition.
19. We will only allow new plastic pipes and manholes where the existing sewers are constructed in plastic. All new plastic pipes constructed must be British Standards kite marked to BS EN 13476.

Contact us



Further information:

www.developers.thameswater.co.uk

Email us at:

developer.services@thameswater.co.uk



0800 009 3921

Monday to Friday, 8am to 5pm



Thames Water Developer Services

Clearwater Court

Vastern Road

Reading

RG1 8DB

